

GigaDevice Semiconductor Inc.

GD30DC1101x
High Efficiency 1.5MHz 1A Synchronous
Step Down Converter

Datasheet

Table of Contents

Table of Contents	2
List of Figures	4
List of Tables	5
1 Features	6
2 Applications	6
3 General description	6
4 Device overview	7
4.1 Device information	7
4.2 Block diagram.....	7
4.3 Pinout and pin assignment	8
4.4 Pin definitions.....	8
5 Functional description	9
5.1 Control loop	9
5.2 Chip enable	9
5.3 Soft start.....	9
5.4 Input over voltage protection	9
5.5 Under voltage lockout.....	9
5.6 Short circuit protection.....	10
5.7 Over current protection	10
5.8 Thermal shutdown	10
6 Application information	11
6.1 Setting up the output	11
6.2 Input capacitor selection	11
6.3 Output capacitor selection	12
6.4 Inductor selection	12
7 Electrical characteristics	13
7.1 Absolute maximum ratings	13
7.2 Recommended operation conditions	13
7.3 Electrical sensitivity	13



7.4	Power supplies voltages and currents.....	14
7.5	EN characteristics	14
7.6	Switching regulator characteristics	14
7.7	Typical Characteristic	15
8	Typical application circuit	18
9	Layout guideline	19
10	Package information	20
10.1	SOT23-5/6 package outline dimensions	20
10.2	Thermal characteristics.....	24
11	Ordering information.....	25
12	Revision history.....	26

List of Figures

Figure 4-1 Block diagram for GD30DC1101x	7
Figure 4-2 GD30DC1101x pinouts.....	8
Figure 6-1 Feedback resistor divider.....	11
Figure 8-1 Typical GD30DC1101x 1.8V output application circuit.....	18
Figure 9-1 Typical GD30DC1101x layout guideline	19
Figure 10-1 SOT23-5 package outline.....	20
Figure 10-2 SOT23-5 recommend footprint	21
Figure 10-3 SOT23-6 package outline.....	22
Figure 10-4 SOT23-6 recommend footprint	23

List of Tables

Table 4-1. Device information for GD30DC1101x.....	7
Table 4-2. GD30DC1101x pin definitions.....	8
Table 6-1 Absolute maximum ratings	13
Table 6-2 Recommended operation conditions.....	13
Table 6-3 Electrostatic Discharge and Latch-up characteristics.....	13
Table 6-4 Power supplies voltages and currents	14
Table 6-5 EN characteristics	14
Table 6-6 Switching regulator characteristics	14
Table 8-1 Components parameter recommend	18
Table 10-1 SOT23-5 dimensions.....	20
Table 10-2 SOT23-6 dimensions.....	22
Table 10-3. Package thermal characteristics ⁽¹⁾	24
Table 11-1 Part order code for GD30DC1101x devices	25
Table 12-1 Revision history	26

1 Features

- 2.5V to 5.5V Input Voltage Range
- 0.6V Reference Voltage
- 1A Output Current
- Low $R_{DS(ON)}$ 250/200m Ω (High/Low Side)
- 1.5MHz Switching Frequency
- Internal 0.7ms Soft-Start Time
- Internal Compensation Function
- 100% Duty Cycle
- Input Over Voltage Protection
- Over Current Protection
- Hiccup Short Circuit Protection
- Over Temperature Protection
- RoHS Compliant and Halogen Free

2 Applications

- Set TopBox
- LCD TV & Table
- AP Router & Wifi
- G-PON, E-PON, xDSL

3 General description

The GD30DC1101x is a high efficiency, high frequency synchronous DC-DC step-down converter. The 100% duty cycle feature provides low dropout operation, extending battery life in portable systems.

The internal synchronous switch increases efficiency and eliminates the need for external schottky diode. At shutdown mode, the input supply current is less than 1 μ A.

The GD30DC1101x fault protection includes input over-voltage protection, over-current protection, short circuit protection, UVLO and thermal shutdown. The Internal soft-start function prevents inrush current at turn-on. The GD30DC1101x is offered in SOT23-5 and SOT23-6 Packages.

4 Device overview

4.1 Device information

Table 4-1. Device information for GD30DC1101x

	Package	Function	Description
GD30DC1101x	SOT23-5	Buck	High efficiency 1.5MHz 1A synchronous step down converter
	SOT23-6		

4.2 Block diagram

Figure 4-1 Block diagram for GD30DC1101x

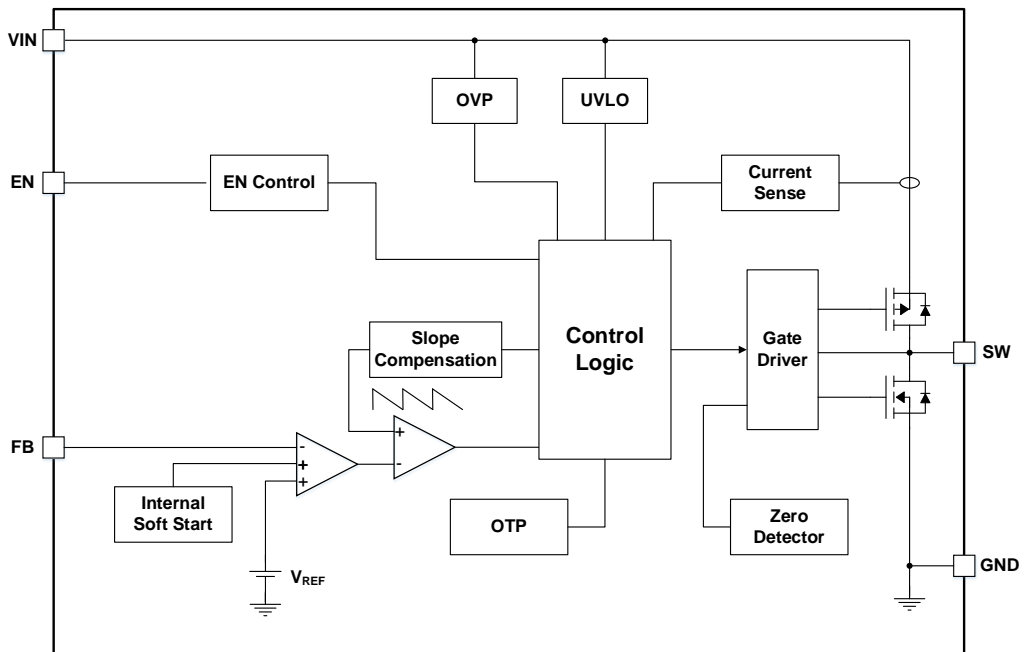

4.3 Pinout and pin assignment

Figure 4-2 GD30DC1101x pinouts

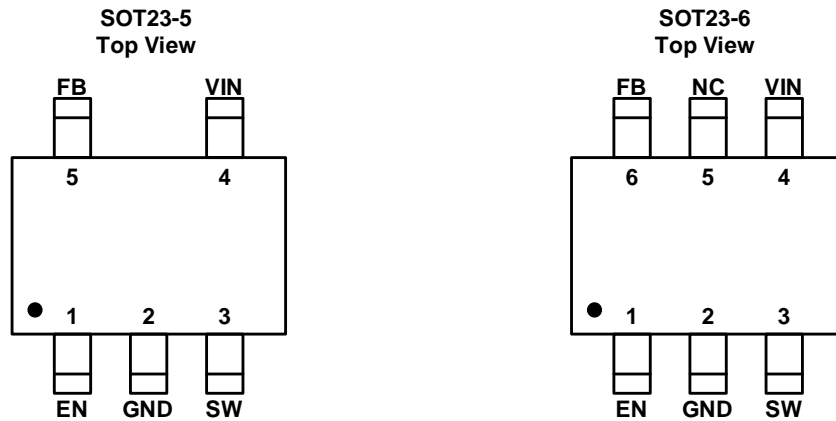

4.4 Pin definitions

Table 4-2. GD30DC1101x pin definitions

Pin Name	Pins		Pin Type	Functions description
	SOT23-5	SOT23-6		
EN	1	1	I	Enable control pin. Pull high to turn the IC on, and pull low to disable the IC. Don't leave this pin floating.
GND	2	2	G	Device ground.
SW	3	3	P	Power switching node. Connect an inductor to the drains of internal high side PMOS and low side NMOS.
VIN	4	4	P	Power supply input pin. Placed input capacitors as close as possible from VIN to GND to avoid noise influence.
NC	-	5	-	No connection pin for GD30DC1101x.
FB	5	6	I	Feedback pin for the internal control loop. Connect this pin to the external feedback divider.

Notes:

(1) Type: I = input, O = output, I/O = input or output, P = power, G = Ground.

5 Functional description

5.1 Control loop

Slope compensated current mode PWM control provides stable switching and cycle-by-cycle current limit for superior load, line response, protection of the internal main switch and synchronous rectifier. The GD30DC1101x switches at a constant frequency and regulates the output voltage. During each cycle, the PWM comparator modulates the power transferred to the load by changing the inductor peak current based on the feedback error voltage. During normal operation, the main switch is turned on for a certain time to ramp the inductor current at each rising edge of the internal oscillator, and switched off when the peak inductor current is above the error voltage. When the main switch is off, the synchronous rectifier will be turned on immediately and stay on until next cycle starts.

5.2 Chip enable

The GD30DC1101x EN pin provides digital control to turn on/off the regulator. When the voltage of EN exceeds the threshold voltage, the regulator will start the soft start function. If the EN pin voltage is below the shutdown threshold voltage, the regulator will turn into the shutdown mode and the shutdown current will be smaller than 1 μ A. For auto start-up operation, connect EN to VIN.

5.3 Soft start

The GD30DC1101x employs internal soft start function to reduce input inrush current during start up. The internal soft start time will be 1ms.

5.4 Input over voltage protection

The GD30DC1101x supports input over voltage protection. When input voltage exceeds the input over-voltage threshold 6.1V(typical), the regulator will be shutdown unless the input over voltage is removed. The hysteric of the input OVP comparator is 300mV (typical).

5.5 Under voltage lockout

When the GD30DC1101x is power on, the internal circuits will be held inactive until VIN voltage exceeds the UVLO threshold voltage. And the regulator will be disabled when VIN is below the UVLO threshold voltage. The hysteric of the UVLO comparator is 200mV (typical).

5.6 Short circuit protection

The GD30DC1101x provides short circuit protection function to prevent the device damaged from short condition. When the short condition occurs and the feedback voltage drops lower than 40% of the regulation level, the oscillator frequency will be reduced and hiccup mode will be triggered to prevent the GD30DC1101x from overheating during the extended short condition. Once the short condition is removed, the frequency and current limit will return to normal.

5.7 Over current protection

The GD30DC1101x over current protection function is implemented by using cycle-by-cycle current limit architecture. The inductor current is monitored by measuring the high-side MOSFET series sense resistor voltage. When the load current increases, the inductor current will also increase. When the peak inductor current reaches the current limit threshold, the output voltage will start to drop. When the over current condition is removed, the output voltage will return to the regulated value.

5.8 Thermal shutdown

The GD30DC1101x enters thermal shutdown once the junction temperature exceeds typically 150°C (typical). Once the device temperature falls below the threshold with hysteresis 20°C (typical), the device returns to normal operation automatically.

6 Application information

6.1 Setting up the output

An external resistor divider is used to set output voltage. By selecting R1 and R2, the output voltage is programmed to the desired value. When the output voltage is regulated, the typical voltage at the FB pin is $V_{FB} = 0.6V$.

$$V_{OUT} = V_{FB} * \left(1 + \frac{R_1}{R_2}\right)$$

It is recommended for R2 is 100KΩ.

Figure 6-1 Feedback resistor divider

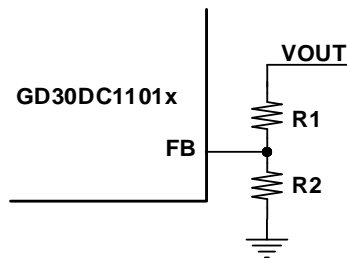

6.2 Input capacitor selection

Input capacitance, C_{IN} , is needed to filter the pulsating current at the drain of the high-side power MOSFET. C_{IN} should be sized to do this without causing a large variation in input voltage. The peak-to-peak voltage ripple on input capacitor can be estimated as the equation below:

$$I_{CIN(RMS)} = I_{OUT(MAX)} \times \sqrt{D \times (1-D)}$$

The worst-case condition occurs at $V_{IN} = 2V_{OUT}$, shown in Equation below:

$$I_{CIN(RMS)} = \frac{I_{OUT(MAX)}}{2}$$

For simplification, choose an input capacitor with an RMS current rating greater than half of the maximum load current.

The input capacitance value determines the input voltage ripple of the converter. If there is an input voltage ripple requirement in the system, choose an input capacitor that meets the specification.

The input voltage ripple can be estimated with Equation:

$$\Delta V_{IN} = \frac{I_{OUT}}{F_{SW} \times C_{IN}} \times \frac{V_{OUT}}{V_{IN}} \times \left(1 - \frac{V_{OUT}}{V_{IN}}\right)$$

6.3 Output capacitor selection

Output capacitor is required to maintain the DC output voltage. 10uF Ceramic capacitors are recommended.

6.4 Inductor selection

The inductor selection trade-offs among size, cost, efficiency, and transient response requirements. Generally, three key inductor parameters are specified for operation with the device: inductance value (L), inductor saturation current (I_{SAT}), and DC resistance (DCR).

A good compromise between size and loss is to choose the peak-to-peak ripple current equals to 20% to 40% of the IC rated current. The switching frequency, input voltage, output voltage, and selected inductor ripple current determines the inductor value as follows:

$$L = \frac{(V_{IN} - V_{OUT}) \times V_{OUT}}{V_{IN} \times F_{SW} \times \Delta I_L}$$

Once an inductor value is chosen, the ripple current(ΔI_L) is calculated to determine the required peak inductor current.

$$\Delta I_L = \frac{V_{OUT}}{F_{SW} \times L} \left(1 - \frac{V_{OUT}}{V_{IN}} \right) \quad \text{and} \quad I_{L(\text{peak})} = I_{OUT(\text{max})} + \frac{\Delta I_L}{2}$$

7 Electrical characteristics

7.1 Absolute maximum ratings

The maximum ratings are the limits to which the device can be subjected without permanently damaging the device. Note that the device is not guaranteed to operate properly at the maximum ratings. Exposure to the absolute maximum rating conditions for extended periods may affect device reliability.

Table 6-1 Absolute maximum ratings

Symbol	Parameter	Min	Max	Unit
V_{IN}	Input voltage	-0.3	6.5	V
V_{SW}	Switching node voltage (SW)	-0.3	$V_{IN}+0.3$	V
V_{IO}	I/O pin voltage (EN,FB)	-0.3	V_{IN}	V
Thermal characteristics				
T_J	Operating junction temperature	-40	150	°C
T_{stg}	Storage temperature	-55	150	°C
P_{max}	SOT23-5/6 Maximum power dissipation @ $T_A=25^{\circ}C$	—	0.4	W

7.2 Recommended operation conditions

Table 6-2 Recommended operation conditions

Symbol	Parameter	Min	Typ	Max	Unit
V_{IN}	Input voltage	2.5	—	5.5	V
V_{OUT}	Output voltage	0.6	—	V_{IN}	V
I_{OUT}	Output current	—	—	1	A
Thermal characteristics					
T_J	Operating junction temperature	-40	—	125	°C

7.3 Electrical sensitivity

The device is strained in order to determine its performance in terms of electrical sensitivity. Electrostatic discharges (ESD) are applied directly to the pins of the sample. Static latch-up (LU) test is based on I-test methods.

Table 6-3 Electrostatic Discharge and Latch-up characteristics

Symbol	Parameter	Conditions	Value	Unit
$V_{ESD(HBM)}$	Electrostatic discharge voltage (human body model)	$T_A = 25^{\circ}C$; JS-001-2017	±2000	V
$V_{ESD(CDM)}$	Electrostatic discharge voltage (charge device model)	$T_A = 25^{\circ}C$; JS-002-2018	±500	V

7.4 Power supplies voltages and currents

$V_{IN} = V_{EN} = 5V$, $T_J = 25^\circ C$, unless otherwise noted.

Table 6-4 Power supplies voltages and currents

Symbol	Parameter	Conditions	Min	Typ	Max	Unit
$V_{IN(OVP)}$	Input overvoltage protection	—	—	6.1	—	V
I_Q	Quiescent current	$V_{IN} = 5V$, No switching	—	40	—	μA
I_{SHDN}	Shutdown current	EN=0	—	0.1	1	μA
V_{UVLO}	V_{IN} under voltage lockout	V_{IN} falling	1.5	2.0	2.5	V
V_{UVLO_HYS}	V_{IN} under voltage lockout hysteresis	V_{IN} rising to falling threshold	—	0.2	—	V

7.5 EN characteristics

$V_{IN} = V_{EN} = 5V$, $T_J = 25^\circ C$, unless otherwise noted.

Table 6-5 EN characteristics

Symbol	Parameter	Conditions	Min	Typ	Max	Unit
V_{ENL}	EN logic low voltage	$2.5V \leq V_{IN} \leq 5.5V$	—	—	0.4	V
V_{ENH}	EN logic high voltage	$2.5V \leq V_{IN} \leq 5.5V$	1.5	—	—	V

7.6 Switching regulator characteristics

$V_{IN} = V_{EN} = 5V$, $T_J = 25^\circ C$, unless otherwise noted.

Table 6-6 Switching regulator characteristics

Symbol	Parameter	Conditions	Min	Typ	Max	Unit
V_{FB}	Feedback voltage	$V_{IN}=2.5$ to $5.5V$	0.588	0.6	0.612	V
I_{FB}	FB leakage current	$V_{FB}=V_{IN}$	—	0.01	1	nA
R_{PMOS}	Main PMOS switch	—	—	250	—	m Ω
R_{NMOS}	Main NMOS switch	—	—	200	—	m Ω
f_{sw}	Switching frequency	$I_{OUT} = 300mA$	—	1.5	—	MHz
D_{MAX}	Maximum duty cycle	—	—	—	100	%
T_{MIN}	Minimum on time	—	—	50	—	nS
I_{LIM}	PMOS current limit	—	1.3	1.8	—	A
R_{DISCHG}	V_{OUT} discharge resistance	—	—	500	—	Ω
T_{JSD}	Thermal shutdown temperature	Juntion temperature rising	—	150	—	$^\circ C$
		Juntion temperature falling	—	130	—	$^\circ C$

7.7 Typical Characteristic

$V_{IN} = 5V$, $V_{OUT} = 3.3V$, $L = 2.2\mu H$, $T_A = +25^\circ C$, unless otherwise noted.

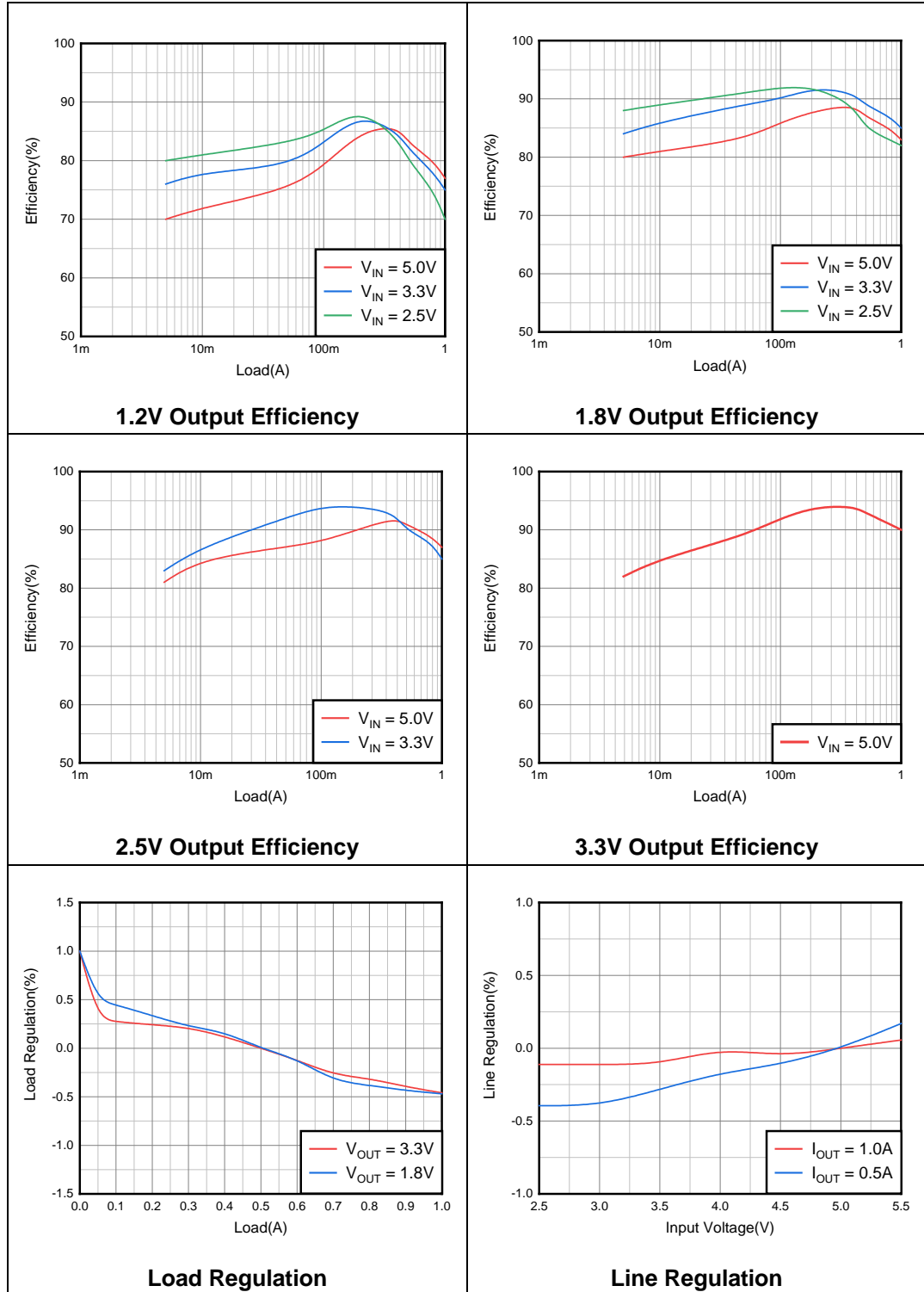

Typical Characteristic(continued)

VIN = 5V, VOUT = 3.3V, L = 2.2uH, TA=+25°C, unless otherwise noted.

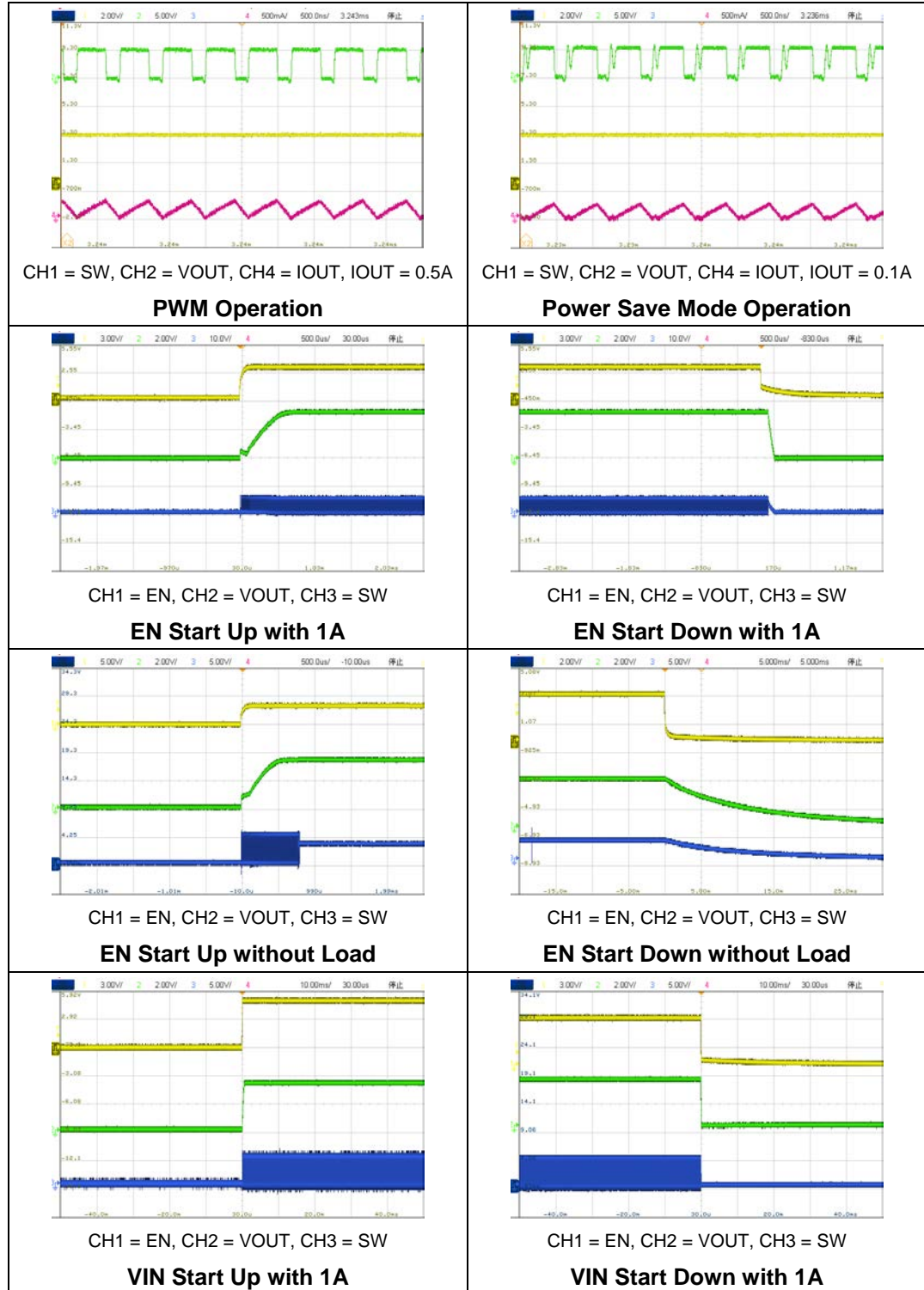

Typical Characteristic(continued)

VIN = 5V, VOUT = 3.3V, L = 2.2uH, TA=+25°C, unless otherwise noted.

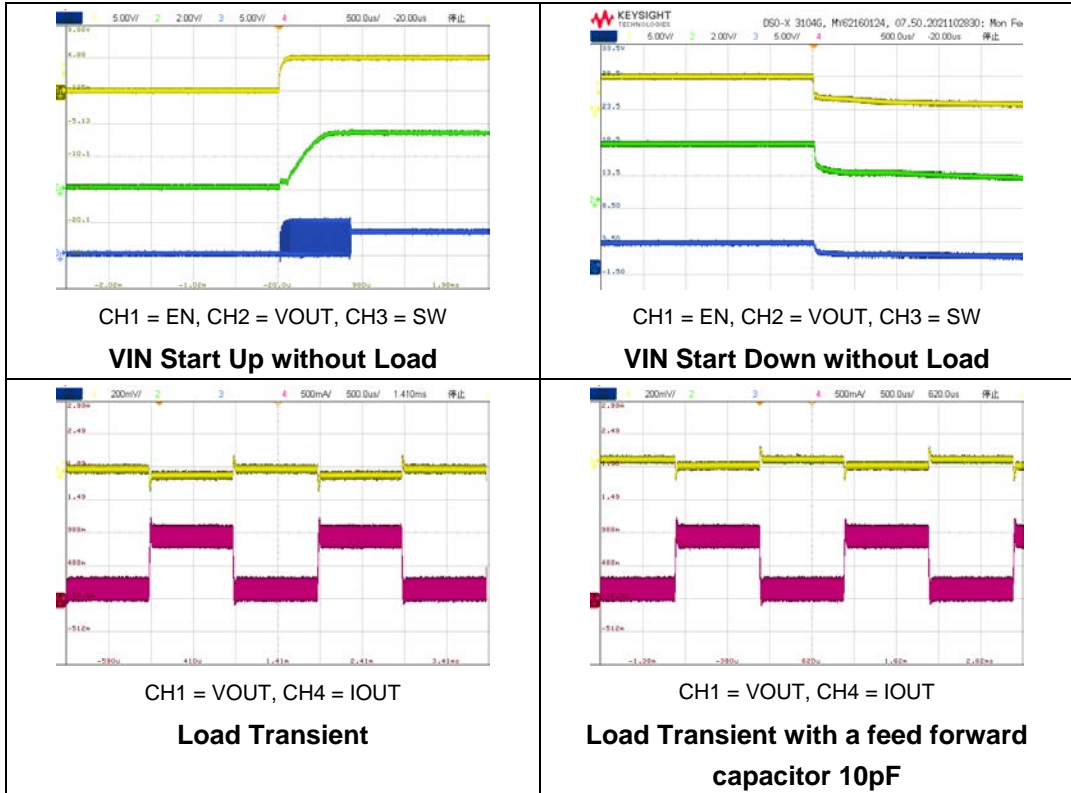

8 Typical application circuit

Figure 8-1 Typical GD30DC1101x 1.8V output application circuit

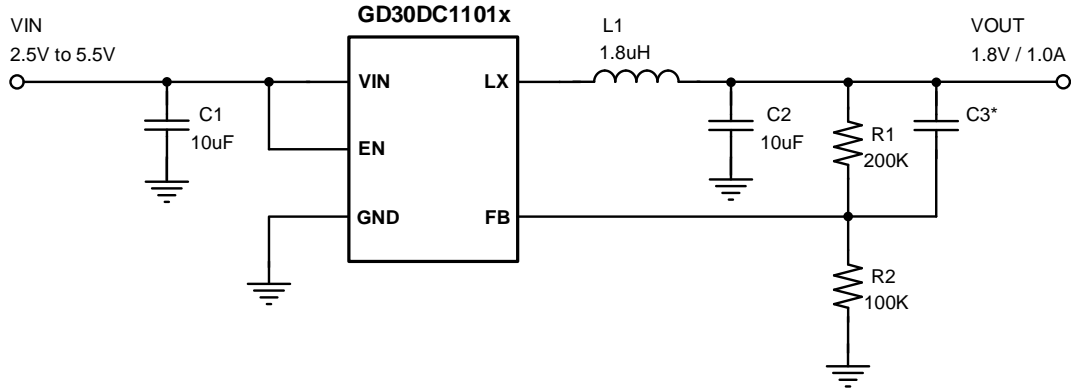

Table 8-1 Components parameter recommend

VOUT	C1	C2	R1	R2	L1
3.3V	10uF MLCC	10uF MLCC	453k	100K	2.2uH
2.5V	10uF MLCC	10uF MLCC	316k	100K	2.2uH
1.8V	10uF MLCC	10uF MLCC	200k	100K	1.8uH
1.5V	10uF MLCC	10uF MLCC	150K	100K	1.5uH
1.2V	10uF MLCC	10uF MLCC	100K	100K	1.5uH
1.05V	10uF MLCC	10uF MLCC	75K	100K	1.2uH

9 Layout guideline

Figure 9-1 Typical GD30DC1101x layout guideline

Efficient PCB layout is critical for stable operation. For the high-frequency switching converter, a poor layout design can result in poor line or load regulation and stability issues. For best results, follow the guidelines below.

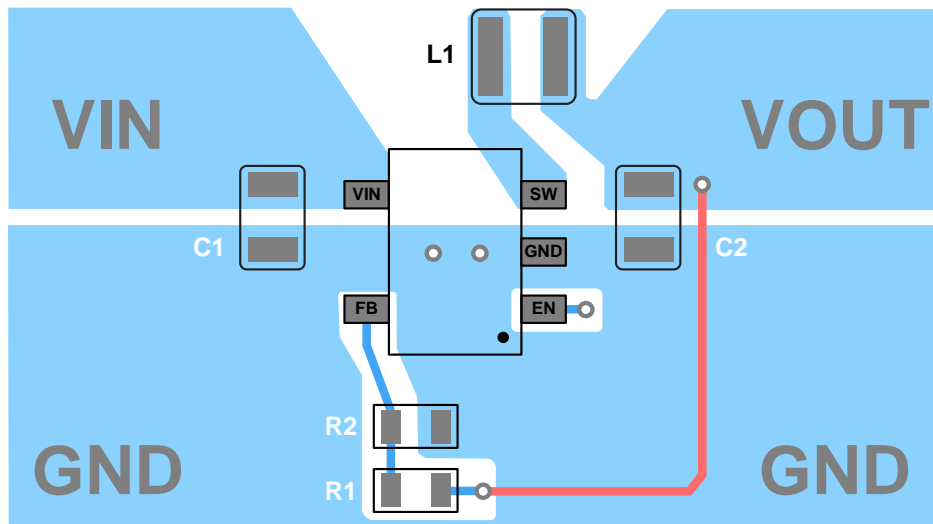

Notes:

- 1) Place the input/output capacitor and inductor should be placed as close to IC.
- 2) Keep the power traces as short as possible.
- 3) The low side of the input and output capacitor must be connected properly to the power GND avoid a GND potential shift.
- 4) Place the external feedback resistors next to FB.
- 5) Keep the switching node SW short and away from the feedback network.

10 Package information

10.1 SOT23-5/6 package outline dimensions

Figure 10-1 SOT23-5 package outline

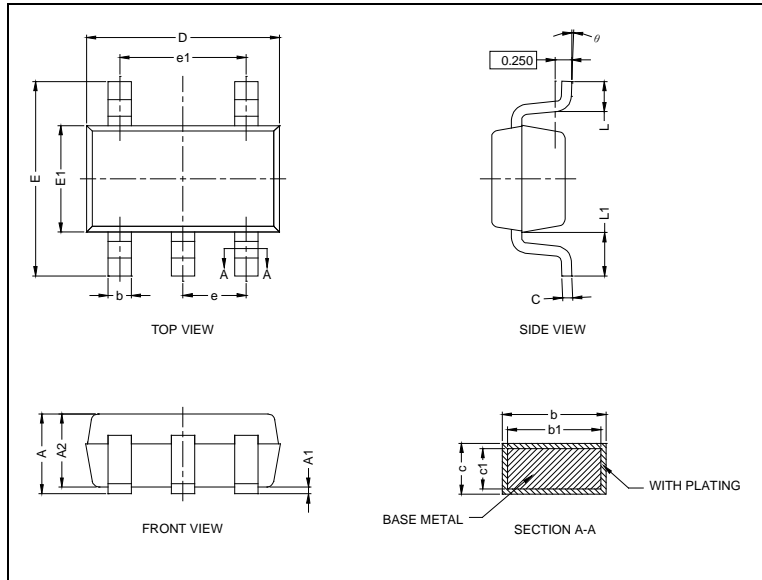
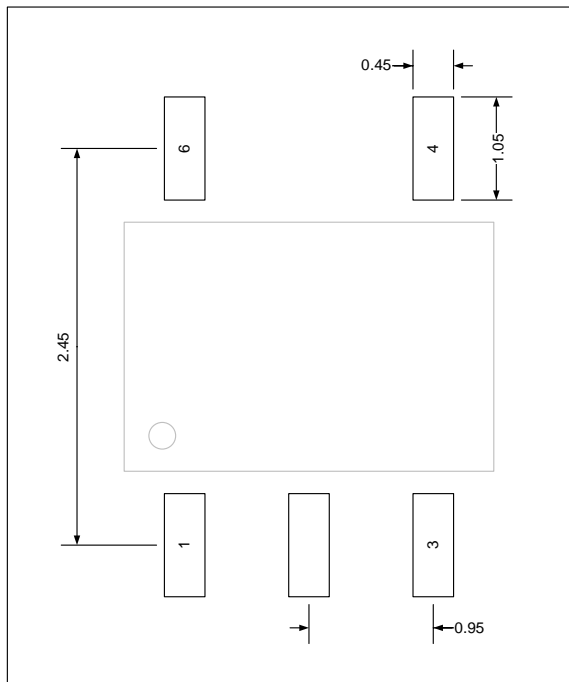

Table 10-1 SOT23-5 dimensions

Symbol	Min	Typ	Max
A	—	—	1.25
A1	0.03	0.08	0.15
A2	1.05	1.10	1.15
b	0.27	—	0.35
b1	0.26	0.285	0.31
c	0.135	—	0.23
c1	0.127	0.152	0.178
D	2.82	2.92	3.02
E	2.60	2.90	3.00
E1	1.50	1.62	1.70
e	0.95 BSC		
e1	1.90 BSC		
L	0.35	0.45	0.55
L1	0.49	0.64	0.79
θ	0°	—	8°

(Original dimensions are in millimeters)

Figure 10-2 SOT23-5 recommend footprint



(Original dimensions are in millimeters)

Figure 10-3 SOT23-6 package outline

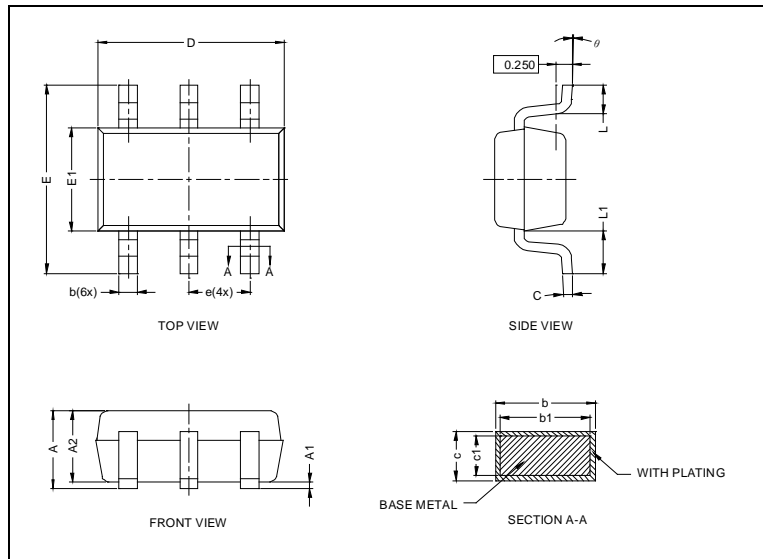
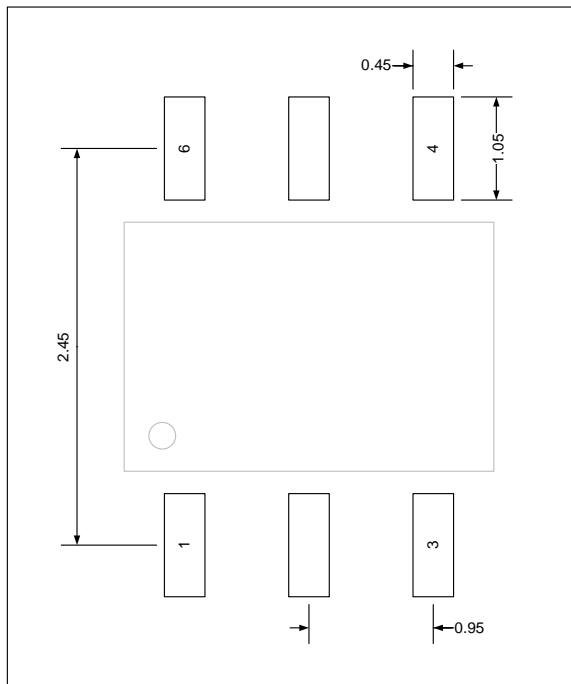

Table 10-2 SOT23-6 dimensions

Symbol	Min	Typ	Max
A	—	—	1.25
A1	0.03	0.08	0.15
A2	1.05	1.10	1.15
b	0.27	—	0.35
b1	0.26	0.285	0.31
c	0.135	—	0.23
c1	0.127	0.152	0.178
D	2.82	2.92	3.02
E	2.60	2.90	3.00
E1	1.50	1.62	1.70
e	0.95 BSC		
e1	1.90 BSC		
L	0.35	0.45	0.55
L1	0.49	0.64	0.79
θ	0°	—	8°

Figure 10-4 SOT23-6 recommend footprint



(Original dimensions are in millimeters)

10.2 Thermal characteristics

Thermal resistance is used to characterize the thermal performance of the package device, which is represented by the Greek letter “ Θ ”. For semiconductor devices, thermal resistance represents the steady-state temperature rise of the chip junction due to the heat dissipated on the chip surface.

Θ_{JA} : Thermal resistance, junction-to-ambient.

Θ_{JB} : Thermal resistance, junction-to-board.

Θ_{JC} : Thermal resistance, junction-to-case.

Ψ_{JB} : Thermal characterization parameter, junction-to-board.

Ψ_{JT} : Thermal characterization parameter, junction-to-top center.

$$\Theta_{JA} = (T_J - T_A)/P_D$$

$$\Theta_{JB} = (T_J - T_B)/P_D$$

$$\Theta_{JC} = (T_J - T_C)/P_D$$

Where, T_J = Junction temperature.

T_A = Ambient temperature

T_B = Board temperature

T_C = Case temperature which is monitoring on package surface

P_D = Total power dissipation

Θ_{JA} represents the resistance of the heat flows from the heating junction to ambient air. It is an indicator of package heat dissipation capability. Lower Θ_{JA} can be considerate as better overall thermal performance. Θ_{JA} is generally used to estimate junction temperature.

Θ_{JB} is used to measure the heat flow resistance between the chip surface and the PCB board.

Θ_{JC} represents the thermal resistance between the chip surface and the package top case.

Θ_{JC} is mainly used to estimate the heat dissipation of the system (using heat sink or other heat dissipation methods outside the device package).

Table 10-3. Package thermal characteristics⁽¹⁾

Symbol	Condition	Package	Value	Unit
Θ_{JA}	Natural convection, 2S2P PCB	SOT23-5/6	117.71	°C/W
Θ_{JB}	Cold plate, 2S2P PCB	SOT23-5/6	59.55	°C/W
Θ_{JC}	Cold plate, 2S2P PCB	SOT23-5/6	34.00	°C/W
Ψ_{JB}	Natural convection, 2S2P PCB	SOT23-5/6	59.46	°C/W
Ψ_{JT}	Natural convection, 2S2P PCB	SOT23-5/6	2.27	°C/W

(1) Thermal characteristics are based on simulation, and meet JEDEC specification.

11 Ordering information

Table 11-1 Part order code for GD30DC1101x devices

Ordering Code	Package	Package Type	Packing Type	MOQ	Temperature Junction Range
GD30DC1101NSTR-I	SOT23-5	Green	Tape&Reel	3000	Industrial -40°C to +125°C
GD30DC1101SSTR-I	SOT23-6	Green	Tape&Reel	3000	Industrial -40°C to +125°C

12 Revision history

Table 12-1 Revision history

Revision No.	Description	Date
1.0	Initial Release	Jun. 21, 2023

Important Notice

This document is the property of GigaDevice Semiconductor Inc. and its subsidiaries (the "Company"). This document, including any product of the Company described in this document (the "Product"), is owned by the Company according to the laws of the People's Republic of China and other applicable laws. The Company reserves all rights under such laws and no Intellectual Property Rights are transferred (either wholly or partially) or licensed by the Company (either expressly or impliedly) herein. The names and brands of third party referred thereto (if any) are the property of their respective owner and referred to for identification purposes only.

The Company makes no representations or warranties of any kind, express or implied, with regard to the merchantability and the fitness for a particular purpose of the Product, nor does the Company assume any liability arising out of the application or use of any Product described in this document. Any information provided in this document is provided only for reference purposes. It is the sole responsibility of the user of this document to determine whether the Product is suitable and fit for its applications and products planned, and properly design, program, and test the functionality and safety of its applications and products planned using the Product. Unless otherwise expressly specified in the datasheet of the Product, the Product is designed, developed, and/or manufactured for ordinary business, industrial, personal, and/or household applications only, and the Product is not designed or intended for use in (i) safety critical applications such as weapons systems, nuclear facilities, atomic energy controller, combustion controller, aeronautic or aerospace applications, traffic signal instruments, pollution control or hazardous substance management; (ii) life-support systems, other medical equipment or systems (including life support equipment and surgical implants); (iii) automotive applications or environments, including but not limited to applications for active and passive safety of automobiles (regardless of front market or aftermarket), for example, EPS, braking, ADAS (camera/fusion), EMS, TCU, BMS, BSG, TPMS, Airbag, Suspension, DMS, ICMS, Domain, ESC, DCDC, e-clutch, advanced-lighting, etc.. Automobile herein means a vehicle propelled by a self-contained motor, engine or the like, such as, without limitation, cars, trucks, motorcycles, electric cars, and other transportation devices; and/or (iv) other uses where the failure of the device or the Product can reasonably be expected to result in personal injury, death, or severe property or environmental damage (collectively "Unintended Uses"). Customers shall take any and all actions to ensure the Product meets the applicable laws and regulations. The Company is not liable for, in whole or in part, and customers shall hereby release the Company as well as its suppliers and/or distributors from, any claim, damage, or other liability arising from or related to all Unintended Uses of the Product. Customers shall indemnify and hold the Company, and its officers, employees, subsidiaries, affiliates as well as its suppliers and/or distributors harmless from and against all claims, costs, damages, and other liabilities, including claims for personal injury or death, arising from or related to any Unintended Uses of the Product.

Information in this document is provided solely in connection with the Product. The Company reserves the right to make changes, corrections, modifications or improvements to this document and the Product described herein at any time without notice. The Company shall have no responsibility whatsoever for conflicts or incompatibilities arising from future changes to them. Information in this document supersedes and replaces information previously supplied in any prior versions of this document.